

**Reverse Engineering**

## Who are we

**AMDengineering** is a young and dynamic company specialized in the **design of mechatronic components and systems**, with a particular focus on additive manufacturing

Born from the twenty-year experience of its founders in the engineering of customized machines, in each of our projects the natural combination of technological innovation, environmental sustainability, robotics, merge to create a high-tech product.

A diverse team, with specific and transversal skills, transforms ideas into reality.



## What is Reverse Engineering?

Reverse Engineering is a process by which a component is reconstructed starting from the three-dimensional scan of the original. The purpose of this process is to create a parametric 3D model that will be used to build or modify the component, which previously had no drawing.

The polygonal model obtained through a 3D scan can be further processed and transformed into mathematical surfaces that can be modelled and manipulated in traditional CAD/CAM environments.

In the Reverse Engineering process, it is possible to distinguish three different types of obtainable surfaces:

- semi-automatic or multi-patch surfaces,
- optimised surfaces,
- engineered (parametric) surfaces.



# The Phases of Reverse Engineering

## 1. 3D SCAN

We scan components using 3D laser or structured light scanners, which create a 3D model in mesh format.

Maximum accuracy: up to 0.025mm

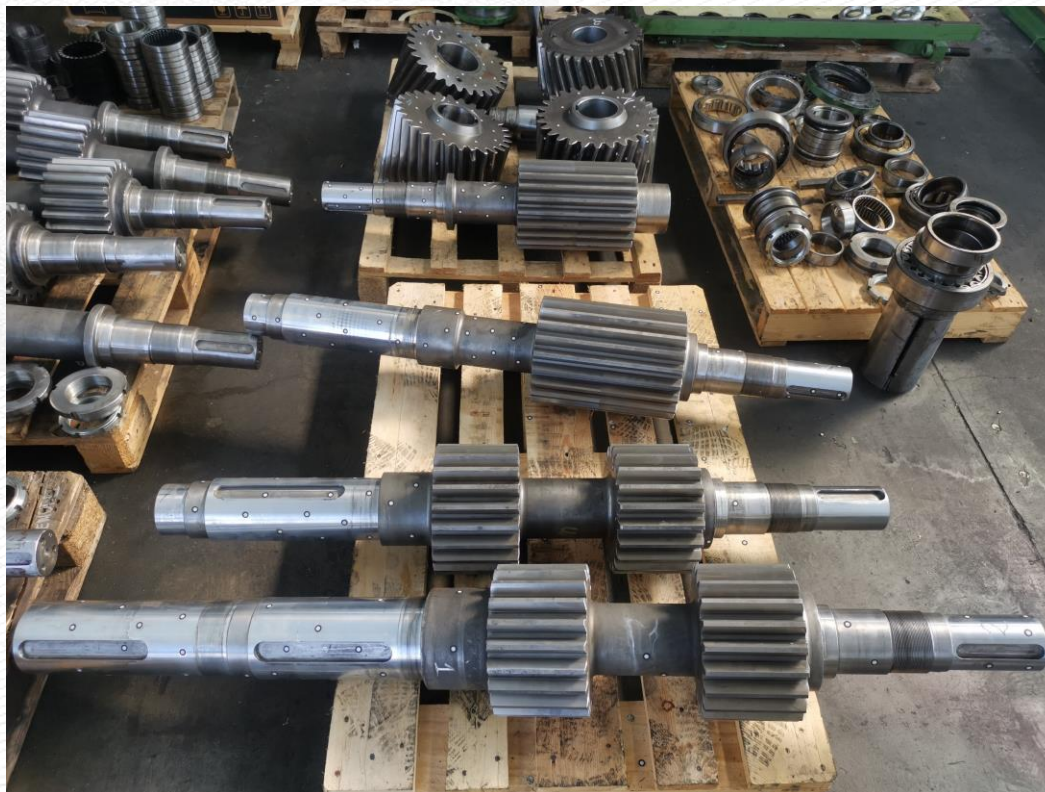



# The Phases of Reverse Engineering

## 2. CREATING POLYGONAL MESH AND CORRECTING ANY ERRORS

After carrying out the 3D scan, WE obtain a file in **polygonal mesh** format (.stl; .obj; .3mf; ...) which will be processed to eliminate any errors and/or defects. The file, once corrected, can be imported into many CAD modeling software to be used as a copying base.

NB: Mesh files are not editable in traditional CAD software and can slow down the software due to their large size.

The polygon mesh can be used, without further steps, for rapid prototyping and **3D printing**.

In order for the CAD software to optimally handle the scanned model, it is possible to convert the scan into surfaces (see next steps).

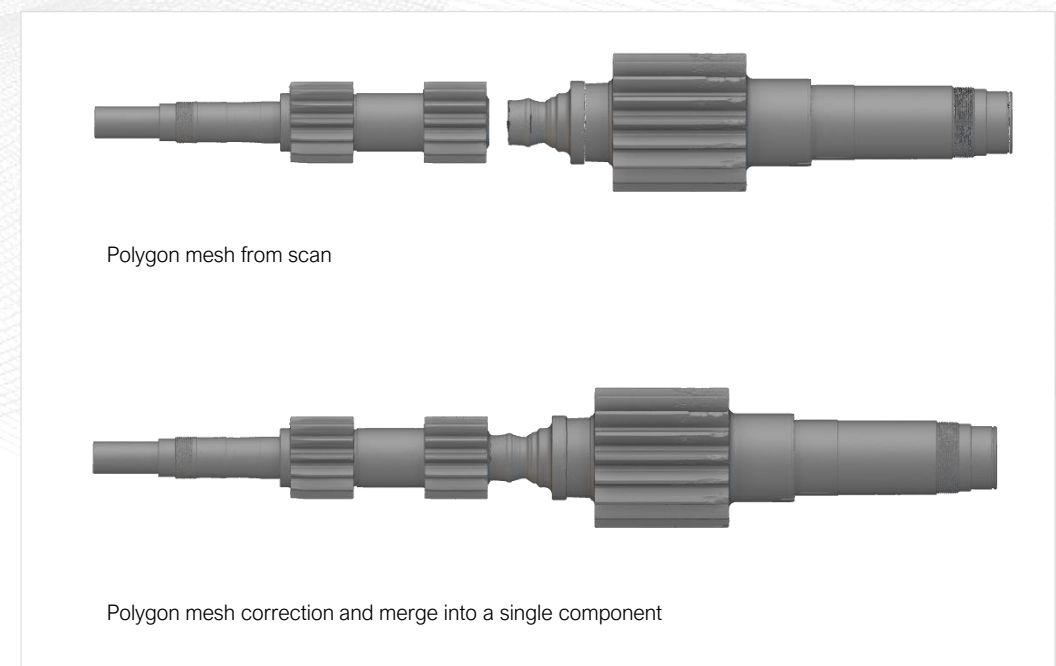
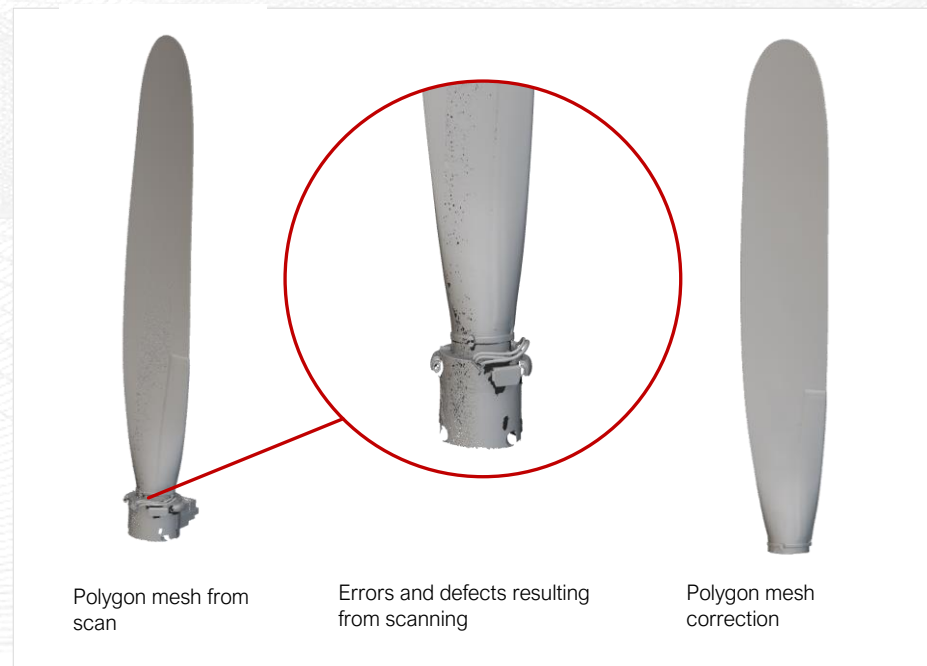

# The Phases of Reverse Engineering

## 3. MULTIPATCH SURFACES

To make the 3D model editable in a CAD environment (not planar surfaces) we process it by making it multipatch.

This type of file is given by the presence of surfaces (NURBS) created semi-automatically by the chosen software, composed of patches and curves with a random and non-parametric arrangement.

They have a high degree of fidelity compared to the scan.

These files, usually in IGES, STEP or PARASOLID format, are more convenient to manage than the .stl scan file.

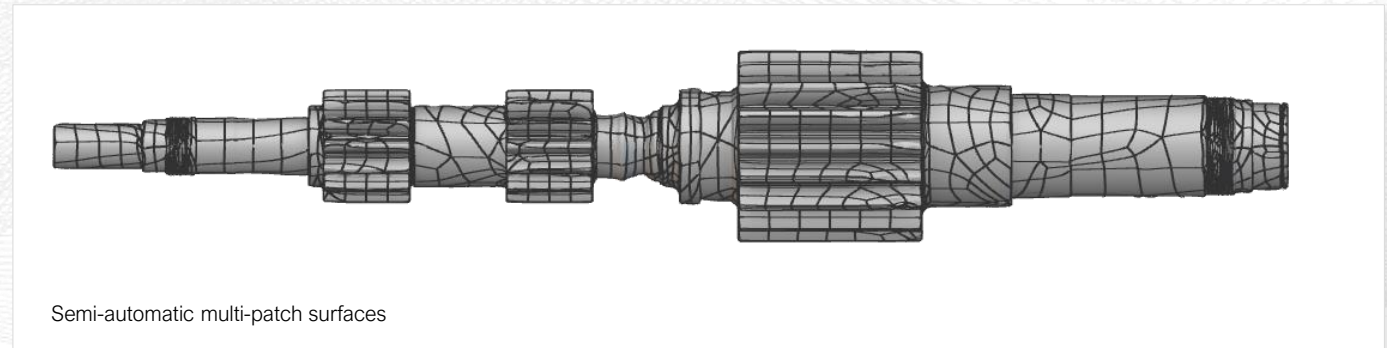
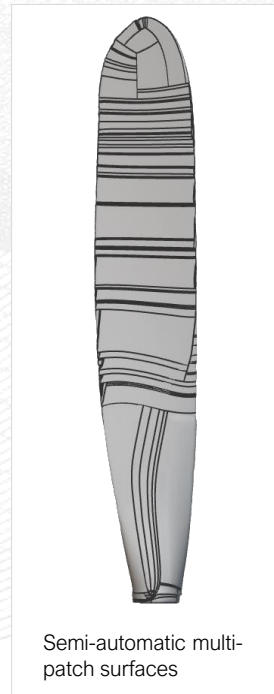

# The Phases of Reverse Engineering

## 4. NURBS OPTIMIZED SURFACES

When the component has organic shapes that cannot be reproduced parametrically, we create optimized NURBS surfaces, which can be manually controlled.

These surfaces are integrated with technical details and traditional parametric geometries.

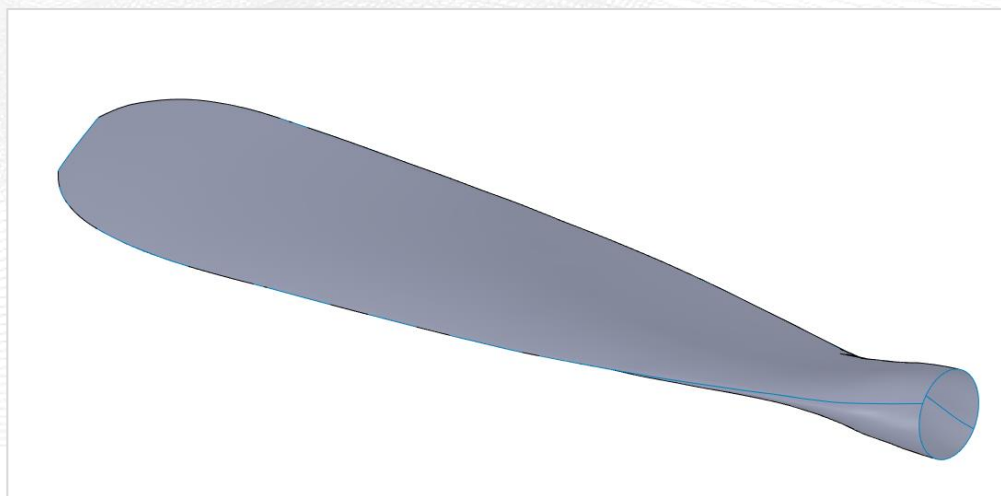
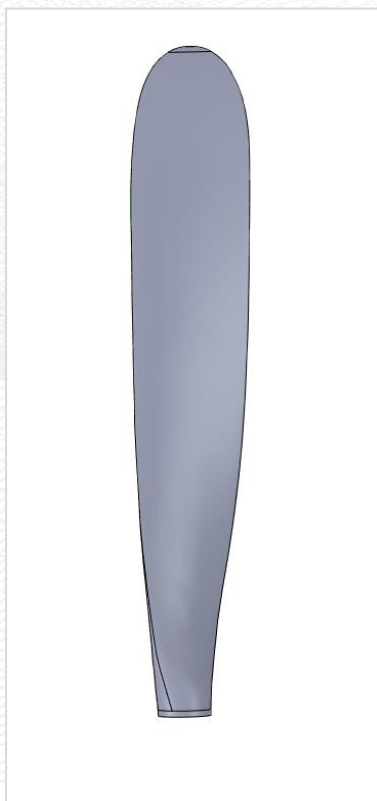



# The Phases of Reverse Engineering

## 5. REBUILT AND ENGINEERED COMPONENT

In the last phase of Reverse Engineering with CAD software, starting from one of the previous phases, the surfaces are completely remodeled, the edges and connections reconstructed.

This creates a component whose **geometry** is easily manageable by CAD and **freely modifiable**.

The reconstruction and engineering of components is useful when it comes to mechanical and technical details.

If the project you are reverse engineering is an assembly, all components will be rebuilt individually.

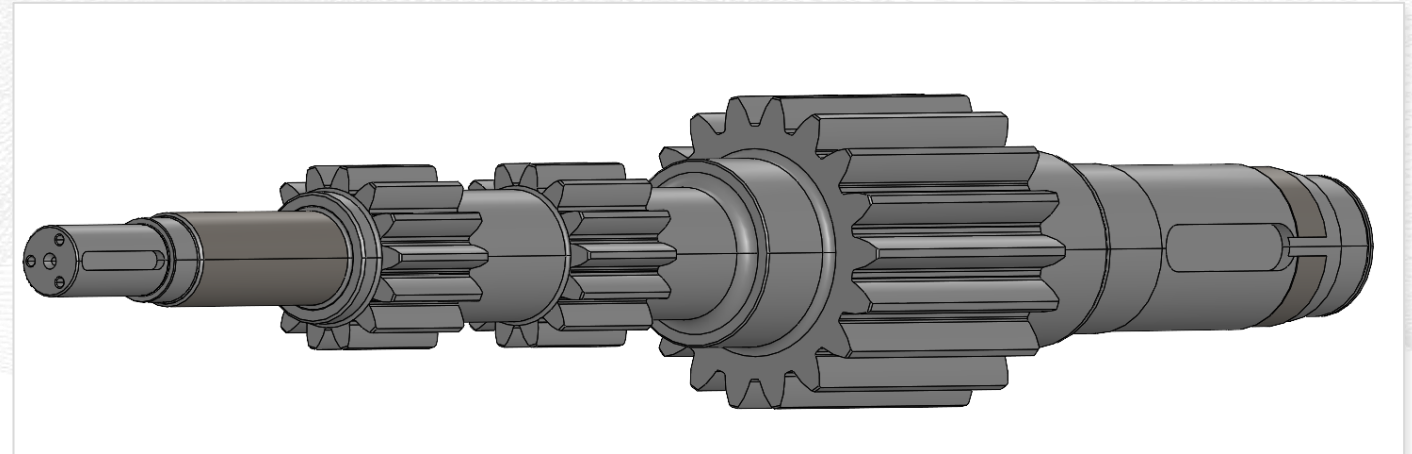
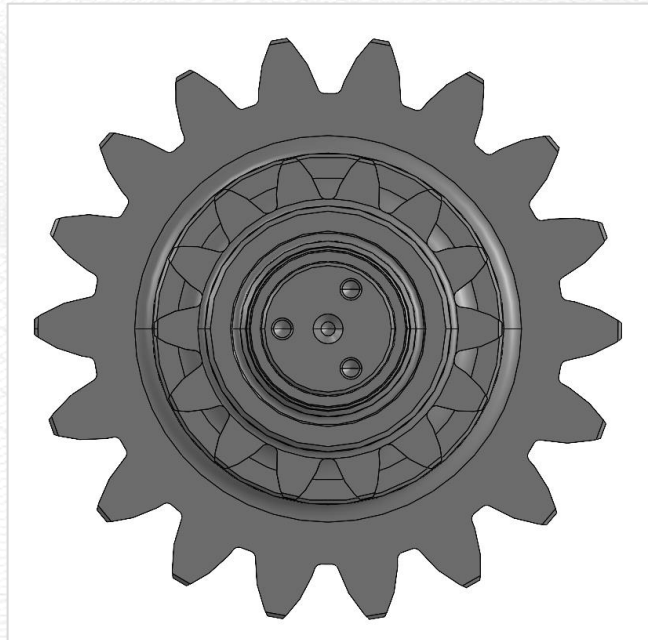



# The Phases of Reverse Engineering

## 6. TECHNICAL DRAWING OF THE COMPONENT

Given our great know-how in mechanical design, we are able to scan an entire machine, composed of multiple parts, providing:

- 2D dimensioned drawings of each component with assembly tolerances;
- Bill of materials, commercial and unified

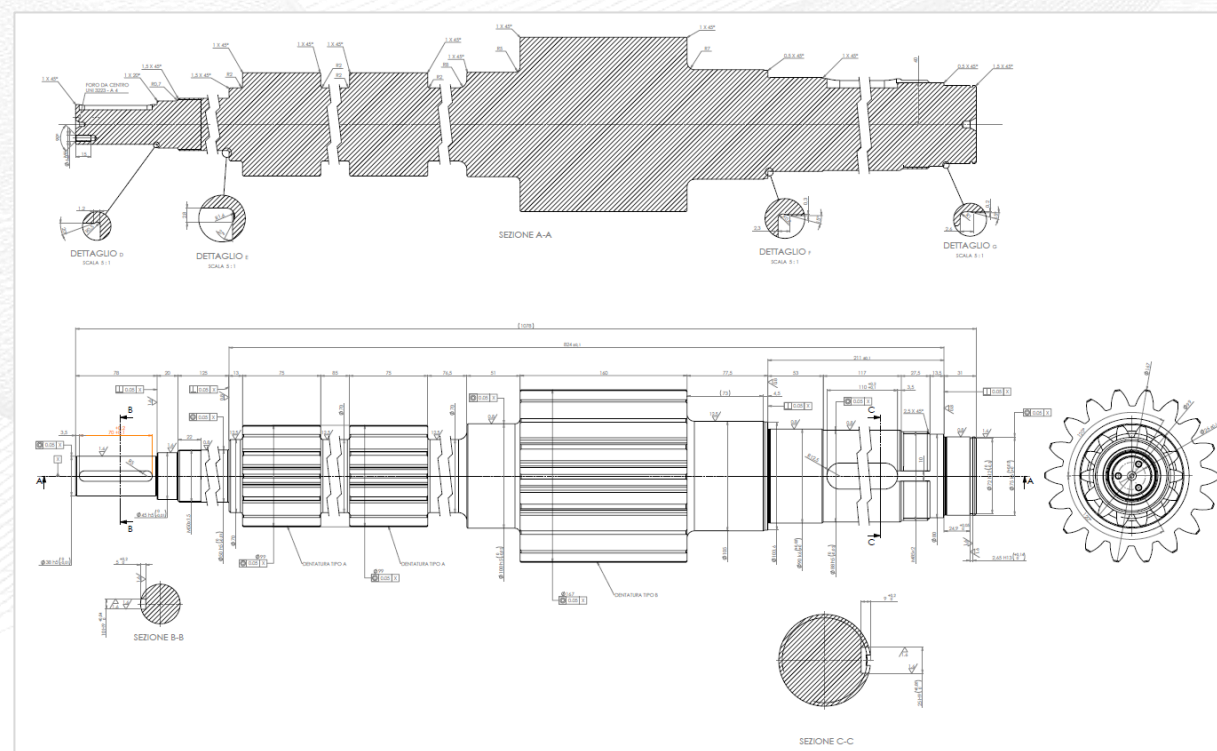

# The Phases of Reverse Engineering

## 6. TECHNICAL DRAWING OF THE ASSEMBLY

If requested, we provide the 3D model, the layout of the entire assembly with the relevant list, commercial and unified.

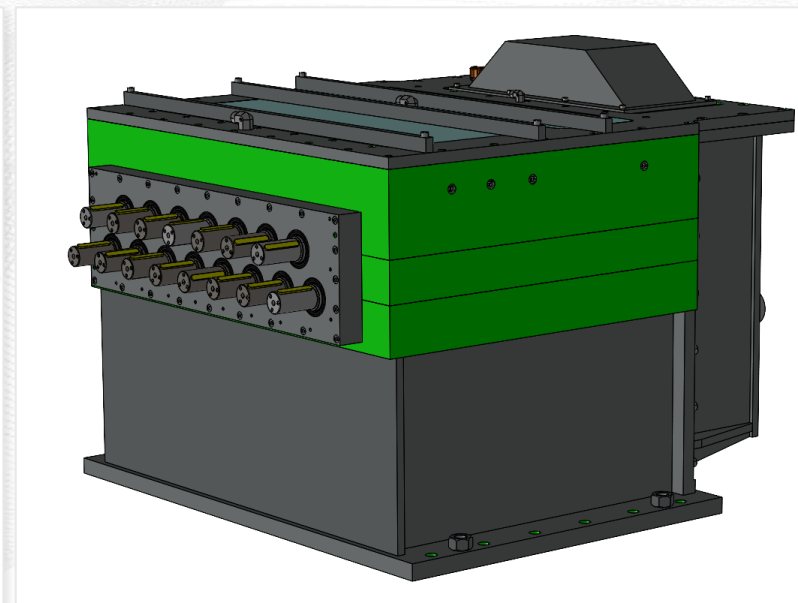
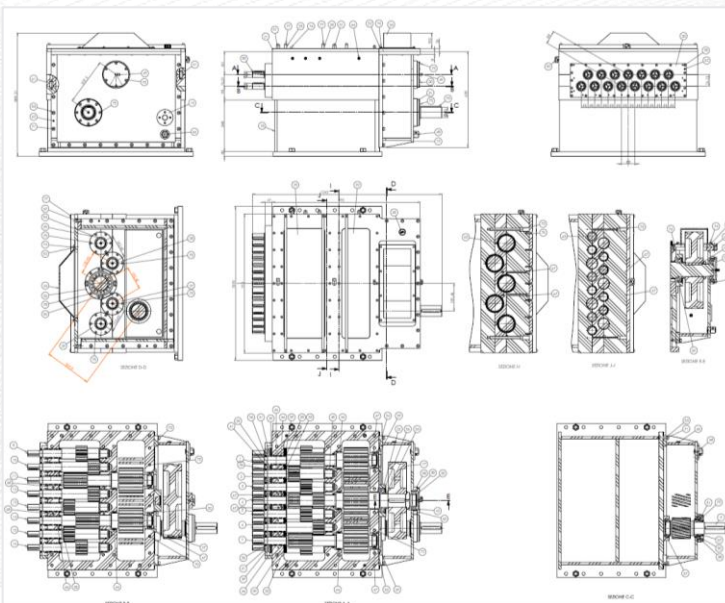



# The Phases of Reverse Engineering

## 6. DEVIATION ANALYSIS

As a quality control: after performing the 3D scan of the component we perform the deviation analysis compared to the supplied CAD model. Following the Reverse Engineering of the component, we perform the above analysis to **evaluate the deviations** from the 3D scan.

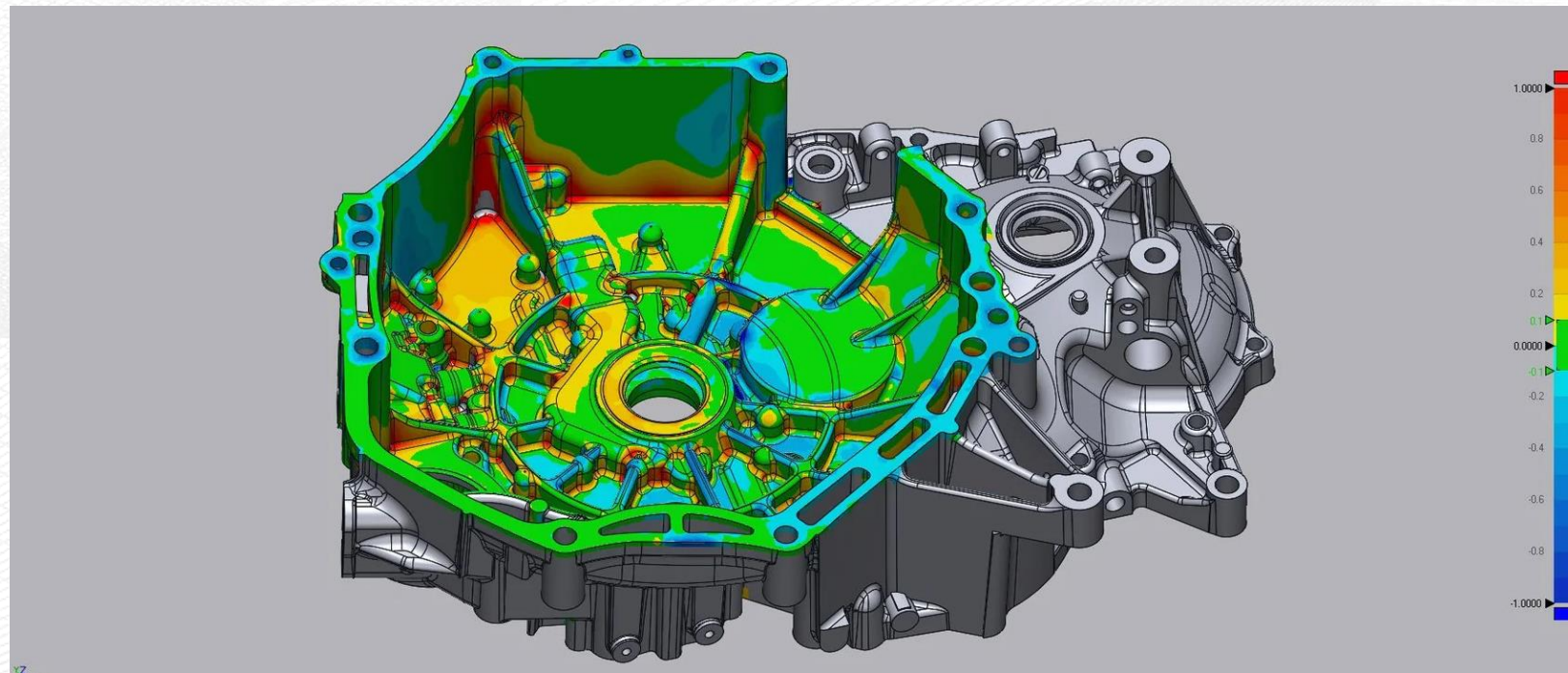

# The Phases of Reverse Engineering

- REPLACEMENT WITH DIRECT ENERGY DEPOSITION

Thanks to our Partners we can offer this service for:

- Pinion toothing;
- Reducer case bearing seats;
- Shaft support bearing seats;
- Oleodynamic cylinder bearing seats;
- Epicyclic gear train planet gear seats;
- Engine cylinder seal seat;
- Roller with hub pulley;
- Spherical seat bearing;
- Pump shaft, split key and keying seizing-up;
- Star valve;
- Reducer shaft;
- Flange;
- Guide shoe;
- Auger;
- Blade;
- Impeller;
- Mobile seal.





# Other examples

3D Scan



Multipatch

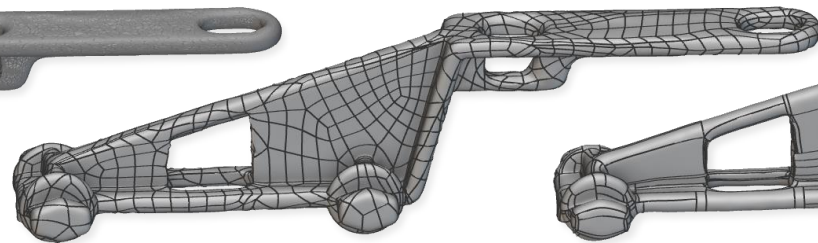

NURBS Surfaces

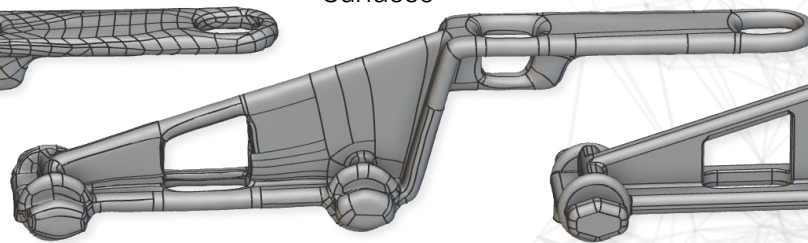

Reverse Engineering

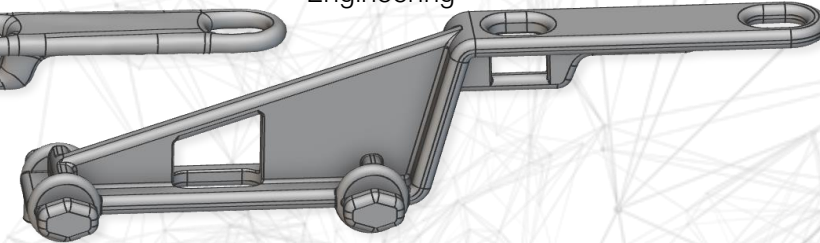

3D Scan

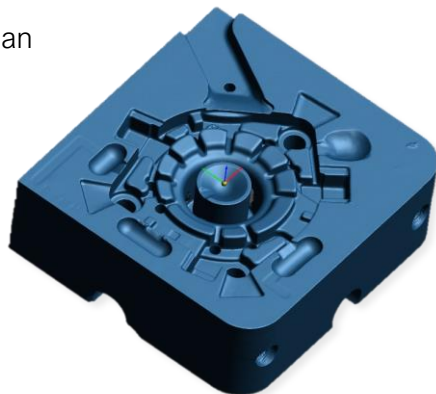

Multipatch

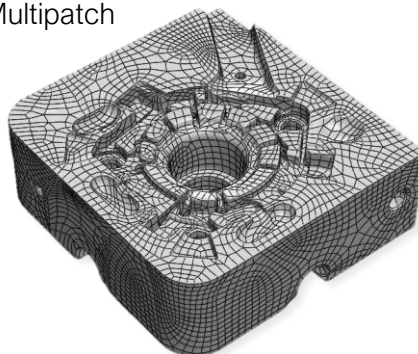

Reverse Engineering

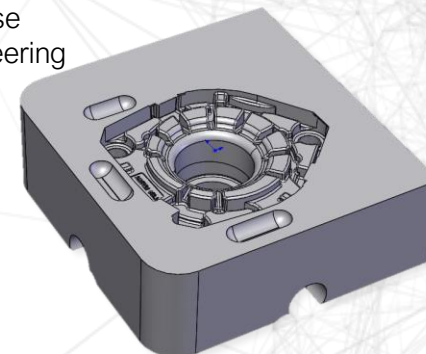

3D Scan

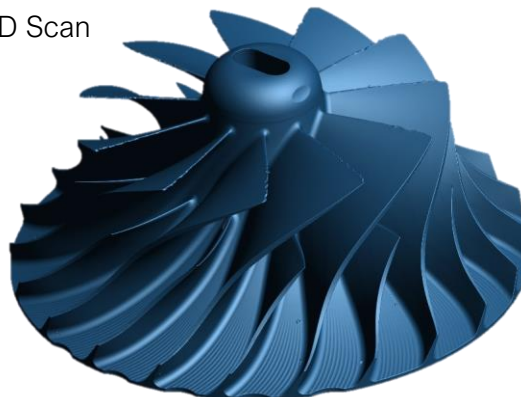

*Low profile, high performance*

